

Call Point Stopper



Protective cover to prevent malicious or accidental damage to electrical switches and call points

This new Call Point Stopper is an aesthetic inexpensive product, which provides a secure fit to a wide range of electrical switches and call points. The cover prevents misuse of the device without restricting legitimate operation. It is ideal for schools, colleges, hospitals, nursing homes, hotels and all public buildings where there is a risk of malicious or accidental activation.

How it Works

The Call Point Stopper consists of a clear tough polycarbonate hinged cover that retrofits securely over the device. Simply lift the cover to gain access to the device. Once the cover is released the spring loaded hinge returns the cover to its original position.



STI 6930



STI Call Point Stopper Colours Available

Features

- Constructed from tough clear polycarbonate.
- Easy to install, can retrofit over an existing device.
- Spring loaded hinge mechanism
- Available in red, yellow and green
- Protects equipment from accidental operation, vandalism & product misuse.
- Available for flush or surface mounted applications.

Part Numbers

STI 6930	Call Point Stopper flush mounted
STI 6931	Call Point Stopper surface mounted
STI 6903	35 mm spacer (supplied with STI 6931)
COLOURS AVAILABLE	The Call Point Stopper is supplied in red as standard, other colours are available. Add /Y or/G to the end of the product code.
EXAMPLE	STI 6931/G = Green Call Point Stopper surface mounted



Hoyles Electronic Developments Ltd

T. 01744 886600 F. 01744 886607 E. sales@hoyles.com W. www.hoyles.com

Dimensions and Technical Information

Installation Instructions

Flush Mount Application

- Position the New Mini Stopper centrally over the device to be protected and mark the position for the two fixing holes. Using a 5mm masonry drill bit, drill the marked holes and insert the size 4-8 rawl plugs provided.
- Secure the cover to the wall only with the fixings provided.

Surface Mount Application

- The surface spacer provides cable entry facilities for conduit, cable and trunking. Depending on the method of installation, fit the required inserts into the spacer.
- Place the spacer centrally over the device to be protected and mark the position for the four fixing holes. Using a 7mm masonry drill bit, drill the marked holes and insert the size 8-12 rawl plugs provided.
- Place the spacer centrally over the device to be protected and mark the position for the four fixing holes. Using a 7mm masonry drill bit, drill the marked holes and insert the size 8-12 rawl plugs provided.
- Fix the spacer to the wall with the four fixing screws provided. Fix the cover to the spacer using the fixings provided (NB: the fixings are already located in the spacer).

Dimensions

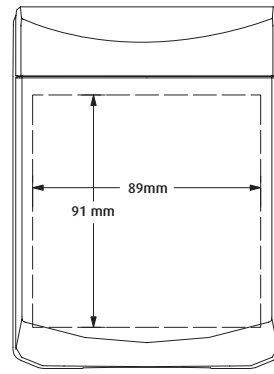

FRONT VIEW

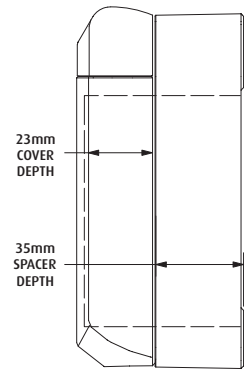

SIDE VIEW

STI 6930 TYPICAL FLUSH INSTALLATION

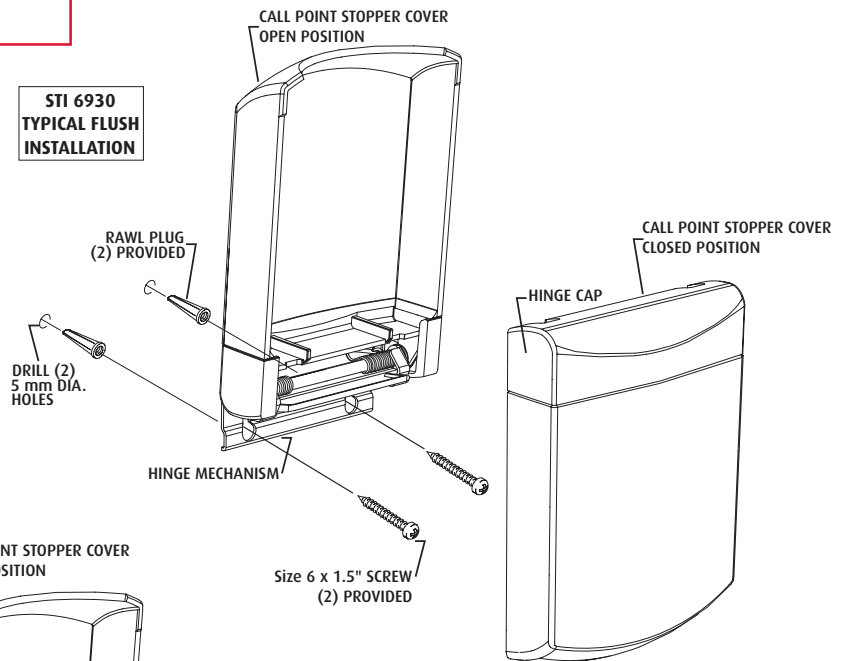

STI 6931 TYPICAL SURFACE INSTALLATION

