

EXITGUARD EX125i-T

The EX125i EXITGUARD is a self contained simple to operate solution for the 24 hour protection of fire exit and other doors.

It is specifically designed to monitor a door contact with end of line resistors (1k/1k) and provide Fully Supervised Loop outputs to allow the EXITGUARD to be monitored by a suitable intruder panel. Selectable resistors allow the outputs to be configured for different intruder panels.

General Operation

The EX125i is controlled using the built in key switch. With the jumper J2 in the LO position, when the keyswitch is in the **0** (off) position, the protected door maybe opened without generating any form of alarm.

With the jumper J2 in the HI position, when the keyswitch is in the **0** (off) position, the protected door maybe opened without generating a local alarm, but OP1 will signal as alarm if the monitored door contact is opened. (This is useful if the monitored door is programmed as final exit, then the OP1 follows the door opening and closing to set the control panel).

If the key switch is in the **I** (on) position, opening the door will result in a high powered audible alarm from the EXITGUARD, the units two LEDs will also flash. Additionally, the alarm output (OP1) will also provide an alarm condition to an intruder panel. Once in alarm, the only way to reset the EXITGUARD is to turn the keyswitch to the **0** position.

Bleep In Off function

The EX125i includes the Bleep In Off function which while the keyswitch is in the **0** position, causes the EXITGUARD to bleep and flash its LED every 30 seconds. Every ten minutes that the EXITGUARD is left in the **0** position it will also briefly play a louder tone. The Bleep In Off function can be turned on or off using the associated jumper on the PCB.

Alarm Auto Reduction

If the alarm is activated by opening the door when the keyswitch is in the **I** position, once the door is closed for a minimum of 1 minute, the alarm sounder will reduce to a bleep every 30 seconds. During the reduced alarm the LEDs will continue to flash and OP1 will remain in alarm. Should the door be opened again, the full alarm sounder will activate again. If the door remains open, the Auto Reduction feature will not take effect.

Safe Set

To prevent accidental alarm activations, the EX125i incorporates a safe set feature. If the keyswitch is moved from the **0** to the **I** position while the door is still open, a constant tone will be heard and the alarm output OP1 will not change state. The door can then be closed within the next 15 seconds and the EXITGUARD will set without having to move the keyswitch back to the **0** position. However if the door remains open beyond the 15 seconds, the EXITGUARD will go into full alarm and the alarm output OP1 will change to the alarm state.

Keyswitch On / Off Monitoring

The EX125i provides a second output OP2 which can be monitored by an intruder panel. This output indicates the status of the keyswitch. With the keyswitch in position **I**, the normal state is indicated. If the keyswitch is in position **0**, the alarm state is indicated.

Box Tamper

If the box lid is opened OP2 provides a tamper to the intruder panel by going open circuit.

Door Contact Tamper

If the door contact is tampered when the keyswitch is in the **I** position, the EXITGUARD will play a continuous tone and OP1 will change to the alarm state. If the keyswitch is in the **0** position, a door contact tamper will just change OP1 to the alarm state and the tone will not be heard.

Output resistors

The two outputs OP1 and OP2 both have two sets of resistor combinations selectable by four different jumpers on the PCB. With all four jumpers in position A, the alarm resistor is 1K and the EoL resistor is also 1k for OP1 and OP2. With all four jumpers in position B, the alarm resistor is 4K7 and the EoL resistor is 2k2 for OP1 and OP2. Other resistor combinations to suit other intruder panels are available on request.

Power requirements

A continuous supply of 12vdc is required, 15mA max quiescent and 150mA max in alarm.

Connection Details

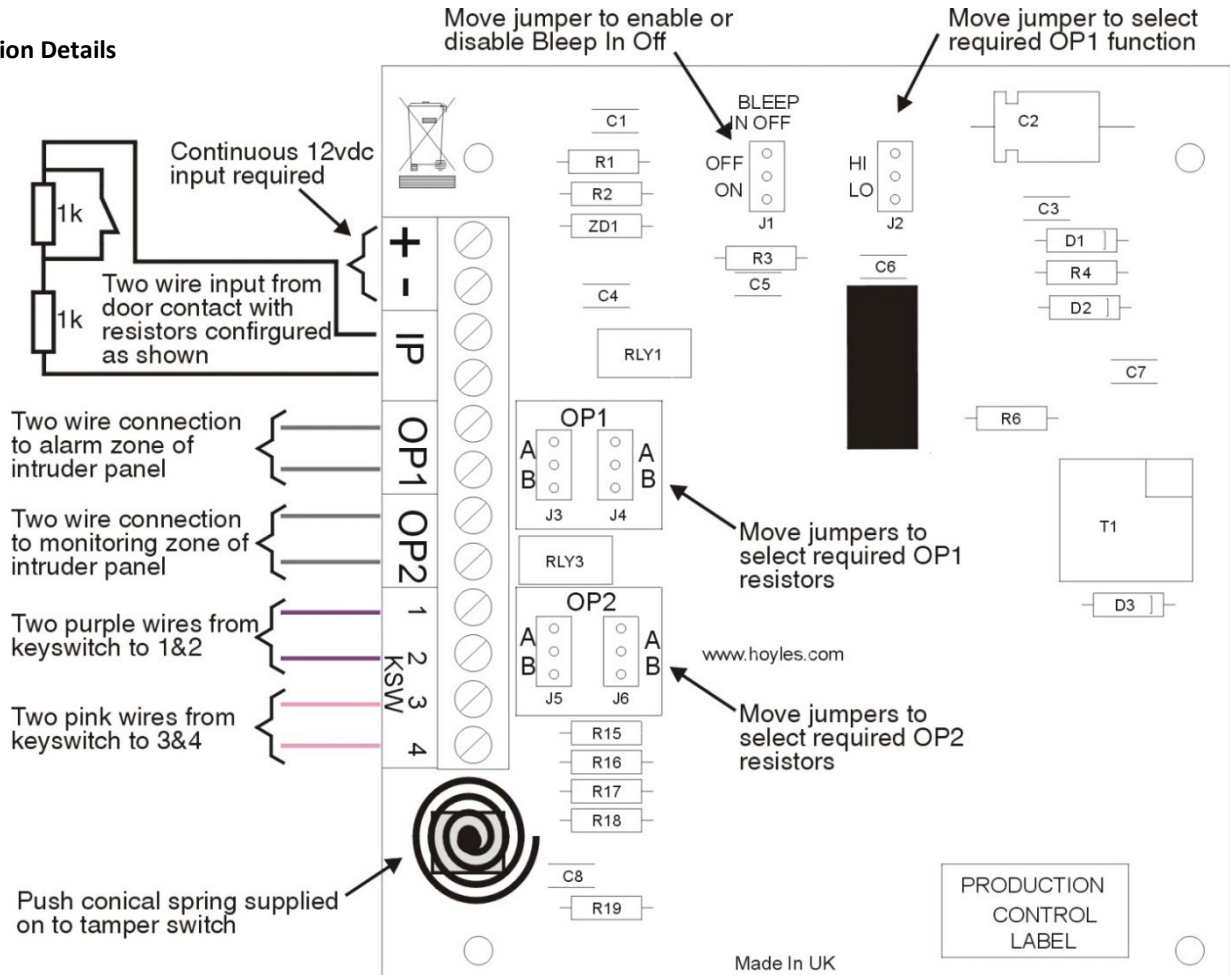

Cause and Event Table

Table shows the possible events based on the available causes.

Causes				Events		
Keyswitch	Door Contact	Box Tamper	J2	Sounder	OP1	OP2
Off	Normal	Closed	Hi	Off or Bleep	Normal	Alarm
Off	Alarm	Closed	Hi	Off or Bleep	Alarm	Alarm
Off	Alarm or Normal	Closed	Lo	Off or Bleep	Normal	Alarm
Off	Alarm or Normal	Open	Lo	Off or Bleep	Normal	O/C Fault
Off	S/C or O/C Fault	Closed	Hi or Lo	Off or Bleep	Alarm	Alarm
Off	S/C or O/C Fault	Open	Hi or Lo	Off or Bleep	Alarm	O/C Fault
On	Normal	Closed	Hi or Lo	Off	Normal	Normal
On	Normal	Open	Hi or Lo	Off	Normal	O/C Fault
On	Alarm	Closed	Hi or Lo	On	Alarm	Normal
On	Alarm	Open	Hi or Lo	On	Alarm	O/C Fault
On	S/C or O/C Fault	Closed	Hi or Lo	On	Alarm	Normal
On	S/C or O/C Fault	Open	Hi or Lo	On	Alarm	O/C Fault

Note: When jumpers for OP1 and OP2 are all set in position A, Normal = 1k and Alarm = 2k (1k+1k)

When jumpers for OP1 and OP2 are all set in position B, Normal = 2k2 and Alarm = 6k9 (2k2+4k7)